



OPERATION & MAINTENANCE MANUAL

For

HVES-CC PUMPS

**PATTERSON PUMP COMPANY
A SUBSIDIARY OF THE GORMAN-RUPP COMPANY
PO Box 790
2129 Ayersville Road
Toccoa, Georgia 30577 USA
Telephone: 706-886-2101
Fax: 706-886-0023**

SAFETY PRECAUTIONS

WARNING

Do not operate this equipment in excess of its rated speed or other than in accordance with the instructions contained in this manual.

The equipment has been found satisfactory for the conditions for which it was sold, but its operation in excess of these conditions may subject it to stresses and strains which it was not designed to withstand.

For equipment covered by this instruction book, it is important to observe safety precautions to protect personnel from possible injury. Among the many considerations, personnel should be instructed to:

- avoid contact with rotating parts
- avoid bypassing or rendering inoperative any safeguards or protective devices
- avoid extended exposure in close proximity to machinery with high noise levels
- use proper care and procedures in handling, lifting, installing, operating and maintaining the equipment
- do not modify this equipment – consult factory if modification is deemed necessary
- do not substitute for repair parts which can be provided by the equipment manufacturer.

Safe maintenance practices with qualified personnel are imperative.

Failure to heed this warning may result in an accident causing personal injury.

INITIAL INSPECTION

Upon delivery of the pumping unit verify that all items on the bill of lading are present. Also verify that the pump unit is not damaged. Immediately report any shortages or any damage to the Freight Company. List the damage or shortages on the bill of lading and the freight bill.

TABLE OF CONTENTS

SECTION I:	General Information	1
SECTION II:	Storage & Protection	1
SECTION III:	Installation	
	3-1 Location	2
	3-2 Mounting	2
	3-3 Alignment.....	2
	3-4 Wiring and Controls	3
SECTION IV:	Operation	
	4-1 Starting.....	3
	4-2 Shutdown	4
SECTION V:	Maintenance	5
SECTION VI:	Repairs & Replacement	
	6-1 To Remove Rotor	7
	6-2 Disassembly of Rotating Element.....	7
	6-3 Cleaning.....	7
	6-4 Inspection.....	8
	6-5 Assembly	8
	Locating Operation Difficulties	9
	Recommended Spare Parts	11
	Typical Assembly Section	12
	Notes	13

SECTION I

GENERAL INFORMATION

This manual covers the installation, operation and maintenance of Patterson Pump HVES-CC pumps. The pump is a centrifugal, single stage; single suction type furnished with mechanical seals. When properly installed and when given reasonable care and maintenance, centrifugal pumps should operate satisfactorily for a long period of time. Centrifugal pumps use the centrifugal force principal of accelerating the liquid within a rotating impeller, and then collecting it and converting it to pressure head in a stationary volute.

The pump consists of two assemblies:

1. Volute assembly or stationary part
2. Rotating element or moving part

The back pullout design allows for removal of the motor and integral rotating element without disturbing the suction and discharge piping. The suction and discharge nozzles are drilled and tapped for gauge connections. Pump casings are drilled and tapped for complete pump drain. Casing wear rings are provided as standard equipment.

SECTION II

STORAGE & PROTECTION

All pumps are shop serviced and ready for operation when delivered, but there are occasions when considerable time elapses between the delivery date and the time the pump is put into operation. Equipment which is not in service should be kept in a clean, dry area. If equipment is to be stored for long periods of time (six months or more), the following precautions should be taken to insure that the equipment remains in good condition.

1. Be sure that the motor bearings are lubricated.
2. Unpainted-machined surfaces, which are subject to corrosion, should be protected by some corrosive resistant coating.
3. The shaft should be rotated 10 to 15 revolutions by hand periodically in order to spread the lubricant over all the bearing surfaces. Suitable intervals are from one to three months, depending on atmospheric conditions, etc. In order to insure that the pump shaft does not begin to sag, do not leave the shaft in the same position each time.
4. Space heaters on motors and controllers should be connected and fully operable if atmospheric conditions approach those experienced in operation. Consult instruction manuals for other precautions concerning storage of individual components of pumping unit.
5. Fresh lubricant should be applied to bearings upon removal of equipment from storage.

SECTION III INSTALLATION

3-1 Location:

Several factors should be considered when selecting a location for the pumping unit (pump and drive). The unit should be accessible for both inspection and maintenance. Headroom should be provided for the use of crane, hoist or other necessary lifting devices. The pump should be located as close as possible to the liquid supply so that the suction line is short and direct. Location should require a minimum of elbows and fittings in the discharge line to minimize friction losses. The unit should be protected against flooding.

3-2 Mounting:

Pumps can be mounted on steel bases, raised concrete pads or floor as long as the mounting surface is level. The mounting surface must be solid and rigid enough to support the pump unit without deflection or vibration. To facilitate the leveling of the pump use a spirit level and short pieces of pipe in the threaded nozzles to determine if the pump is level in all directions.

3-3 Wiring and Controls:

The electric motor power supply connections must conform to national and local codes. The motor ratings stamped on the motor nameplate must match the line voltage and wire capacity. **DO NOT USE ANY OTHER VOLTAGE.**

SECTION IV OPERATION

CAUTION:

Do not exceed the rated working pressure of the pump.

The sum of the suction pressure and the maximum pump operating head (converted to units of pressure) must be less than the pump working pressure, at all times.

CAUTION:

Do not exceed the pressure capabilities of the mechanical seals.

The maximum pressure on the mechanical seal for this pump type is equal to the suction pressure plus 10% of the maximum pump operating head (converted to units of pressure) for a new pump.

For a pump with worn internal ring clearance, the maximum pressure on the mechanical seal is equal to the suction pressure plus 15% of the maximum pump operating head (converted to units of pressure).

This pressure must not exceed the rated working pressure of the mechanical seals.

4-1 Starting:

- When possible, turn the pump shaft by hand to insure that the parts do not bind
- Open the valve in the pump suction line, if fitted
- Close discharge valve
- Prime the pump in one of the following ways:

1. If the pump operates under positive pressure, open vent valve on top of the pump casing. After all entrained air has escaped, close the vent valves. Rotate the shaft, if possible, to allow any air trapped in the impeller passages to escape.

2. If the pump operates on a suction lift and a foot valve is included in the system, fill the pump and the suction line with liquid from an outside source. Trapped air should be allowed to escape through the vent valve while filling.

3. If the pump operates on a suction lift and no foot valve is provided, use a vacuum pump or ejector operated by air, steam, water, etc. to evacuate air from the pump case and suction line by connecting the ejector to the priming connection on top of the pump case.

- Check direction of rotation before starting pump. Rotation should be the same as the direction arrow on the case.

CAUTION:

- Do not operate without liquid. Pump seals depend on the liquid being pumped for lubrication.
- Make sure pump is primed and that no air is in the suction piping and the pump case.
- Make sure all valves open or closed as required by your specific requirements.

Start driver:

Open discharge valve slowly when the pump is up to speed.

CAUTION:

Overheating and/or loss of prime will result if the pump is operated against a closed valve for more than a few minutes.

NOTE: Should the pump fail to build up pressure or discharge water when the discharge valve is opened, stop the pump and read **Section Locating Operating Difficulties**.

4-2 Shutdown:

The pump may be stopped with the discharge valve open without causing damage. However, in order to prevent water hammer effects, as a general recommendation the discharge valve should be closed first.

1. Close discharge valve.
2. Stop driver.
3. If danger of freezing exists, isolate the pump by closing a valve in the pump suction line, if fitted, and drain the pump completely.

**SECTION V
MAINTENANCE**

1. Mechanical seals should be removed, assembled, and/or adjusted according to the seal manufacturer's instructions. There should be no leakage from the volute except for a brief break in period.
2. Check that motor is up to speed; check motor manufacturer instruction for periodic maintenance requirements.
3. Check that electrical control equipment contacts are in good condition and clean.
4. Refer to the "**General Pump Inspection and Maintenance Schedule**" for best results.

General Pump Inspection and Maintenance Schedule HVES-CC Pumps

Excludes drivers, VFD's, and controls.

Contact Patterson Pump Company if assistance is needed to determine the inspection and service requirements for a specific pump.

Inspect (✓) or service (•) at the indicated calendar time or run time interval – whichever comes first	Routinely	Monthly	2000 hours or 3 months	4000 hours or 6 months	8000 hours or 12 months
Unusual noise	✓				
Unusual vibration	✓				
Unusual temperature	✓				
Leaks in pump or piping	✓				
Pressure gauge readings	✓				
Visual inspection of equipment general condition	✓				
Anytime a pump is opened, inspect the running clearances and restore them to original specifications if the running clearances have doubled.	✓ •				
Anytime a pump is opened, inspect the impeller for corrosion or excessive wear.	✓ •				
Mechanical seal (should be no leakage)	✓				
Drain lines are working properly	✓				
Operate the pump		✓			
Perform a comparative field test (flow, pressures and power) with calibrated instruments. Restore internal running clearances if results are unsatisfactory (install new wear rings).					✓ •
Perform a comparative vibration test					✓
Inspect sleeve. Replace if worn.					✓ •

SECTION VI

REPAIRS AND REPLACEMENT

WARNING!!!

Whenever any disassembly work is to be done on the pump, disconnect the power source to the driver to eliminate any possibility of starting unit. It is advisable that a qualified Pump service technician does the disassembly and reassembly of the pump.

6-1 To Remove Rotor:

Reference: Pump Assembly Section

1. Remove bolts holding the motor (19) to base or floor.
2. Remove bolts holding the volute cover (11) to the casing (1).

3. Pull entire rotating assembly and volute cover (11) from the casing (1). The assembly should be pulled straight out until impeller (2) is clear of the casing.

6-2 Disassembly of Rotating Element:

1. Remove the impeller screw (26) and impeller washer (24).
2. Remove impeller (2). Do not loosen impeller key (32).
3. Remove Bolts from between volute cover (11) and motor (19).
4. Remove volute cover (11).
5. Remove mechanical seal (65) and shaft sleeve (14) with o-ring.
6. Remove deflector (40).

6-3 Cleaning:

WARNING!!!

Petroleum based cleaning solvents are flammable. Smoking or open flames in the vicinity of these solvents is extremely hazardous and must not be permitted. Disregarding this warning could result in grave personal injury.

Clean all metal parts with a solvent. Use a bristle brush (not metal or wire) to remove tightly adhering deposits. A fiber scraper may be used to remove the gasket and shellac from casing flange. Blow dry with clean dry compressed air.

CAUTION:

Never use hydrocarbon liquids (oil or solvent) to clean mechanical seal parts. Use of oil or solvent will deteriorate material used on the seal.

Use mild soap solution to clean seal parts. Use only your finger to remove dirt. Rinse with clean water and dry with mild air stream. Use care not to damage or scratch lapped surfaces.

6-4 Inspection:

Visually inspect parts for damage affecting serviceability. Check o-rings and gaskets for cracks, nicks, or tears; packing rings for excessive compression, fraying or shredding, and embedded particles. Replace if defective in any way. Mount shaft between lathe centers and check eccentricity for entire length of the shaft. Eccentricity should not exceed .002 inches (0.05 mm). Bearing surfaces should be smooth; shoulders square and free of nicks.

Measure OD of impeller hub and ID of pump casing. Compute diametrical clearance (ID minus OD) and compare with the original pump specifications. Surfaces must be smooth and concentric. Examine impeller passages for cracks, dents or embedded material. Examine shaft sleeves for wear.

6-5 Assembly:

The following should prove helpful in reassembling the pump:

1. All parts, inside and out, should be clean. Dirt and grit will cause excessive wear, plus needless shutdown.

2. Install the deflector (40) onto the motor shaft (6).
3. Press the mechanical seal (65) into the volute cover (11).
4. Install the volute cover (11) onto the motor (19).
5. Lubricate the O.D. of the shaft sleeve (14) and the I.D. of the opposite half of the mechanical seal using **International Products P-80 Emulsion Temporary Assembly Lubricant** or equivalent (available from International Products Corporation, 201 Connecticut Dr, Burlington NJ 08016 USA, phone 609-386-8770, Fax 609-386-8438, <http://www.ipcol.com>, mkt@ipcol.com) or equivalent. Press the shaft sleeve (14) through the seal. Coat the interior of the shaft sleeve (14) with **Dow Corning 732 Multi Purpose Sealant** or equivalent.
6. Press the shaft sleeve (14) onto the shaft (6) and install seal spring.
7. Insert the impeller key (32) into the shaft (6) keyway. Install the impeller (2) onto the shaft (6).
8. Coat the impeller bolt (26) with **Loctite 262 Threadlocker** or equivalent. Install the impeller washer (24) and bolt (26).
9. Install the casing ring (7) into the casing (1).
10. Install the gasket (73) and position the rotating assembly into the casing (1).
11. Install and tighten casing bolts.
12. Install all NPT fittings and tubing.
13. Rotate by hand when possible to insure that the parts do not bind.

LOCATING OPERATING DIFFICULTIES

In the majority of cases, operating difficulties are external to the pump and the following causes should be carefully investigated before undertaking repairs:

No Water Delivered

- Pump not primed – indicated by no pressure on discharge.
- Speed too low – indicated by low pressure on discharge.
- Valve closed – indicated by high discharge head.
- Impeller completely plugged up – indicated by low discharge pressure.

Abnormally Small Quantities Delivered

- Air leaks in suction pipe or stuffing boxes.
- Speed too low.
- Discharge head higher than anticipated.

- Impeller partially plugged up.
- Obstruction in suction line.
- Mechanical defects: Impeller damaged, casing or seal defective.

Insufficient Pressure

- Speed too low. Might be caused by low voltage or current characteristics different from nameplate reading on the motor.
- Air in water will cause the pump to make a cracking noise.
- Mechanical defects: worn casing rings, impeller damaged, defective casing or seal.

Intermittent Operation

- Leaky suction line.
- Water seal plugged (hence, a leaky stuffing box).
- Suction lift too high.
- Air, gas or vapor in liquid.

Pump Overloads Driver

- Speed too high.
- Head lower than rated, hence, pumping too much water. (This is valid for low specific speed pumps).
- Mechanical defects: stuffing boxes too tight, shaft bent, rotating element binds.
- Rubbing due to foreign matter in the pump between the case ring and the impeller.

Pump Vibrates

- Misalignment.
- Foundation not sufficiently rigid.
- Impeller partially clogged.
- Mechanical defects: bent shaft, rotating element binds, bearings worn, coupling defective.
- Suction and discharge pipes not anchored.
- Pump cavitating from too high a suction lift.

- Air entrainment in the pump suction due to low submergence.

RECOMMENDED SPARE PARTS FOR HVES-CC PUMPS

Reference: Assembly Section

INTERMITTENT DUTY

Number	Description
7	Casing Ring
14	Shaft Sleeve
65	Mechanical Seal
73	Gasket (casing)

CONTINUOUS DUTY

Number	Description
2	Impeller
6	Shaft
7	Casing Ring
14	Shaft Sleeve
26	Impeller Screw
40	Deflector
65	Mechanical Seal
	All Hardware (not shown)
73	Gasket (casing)

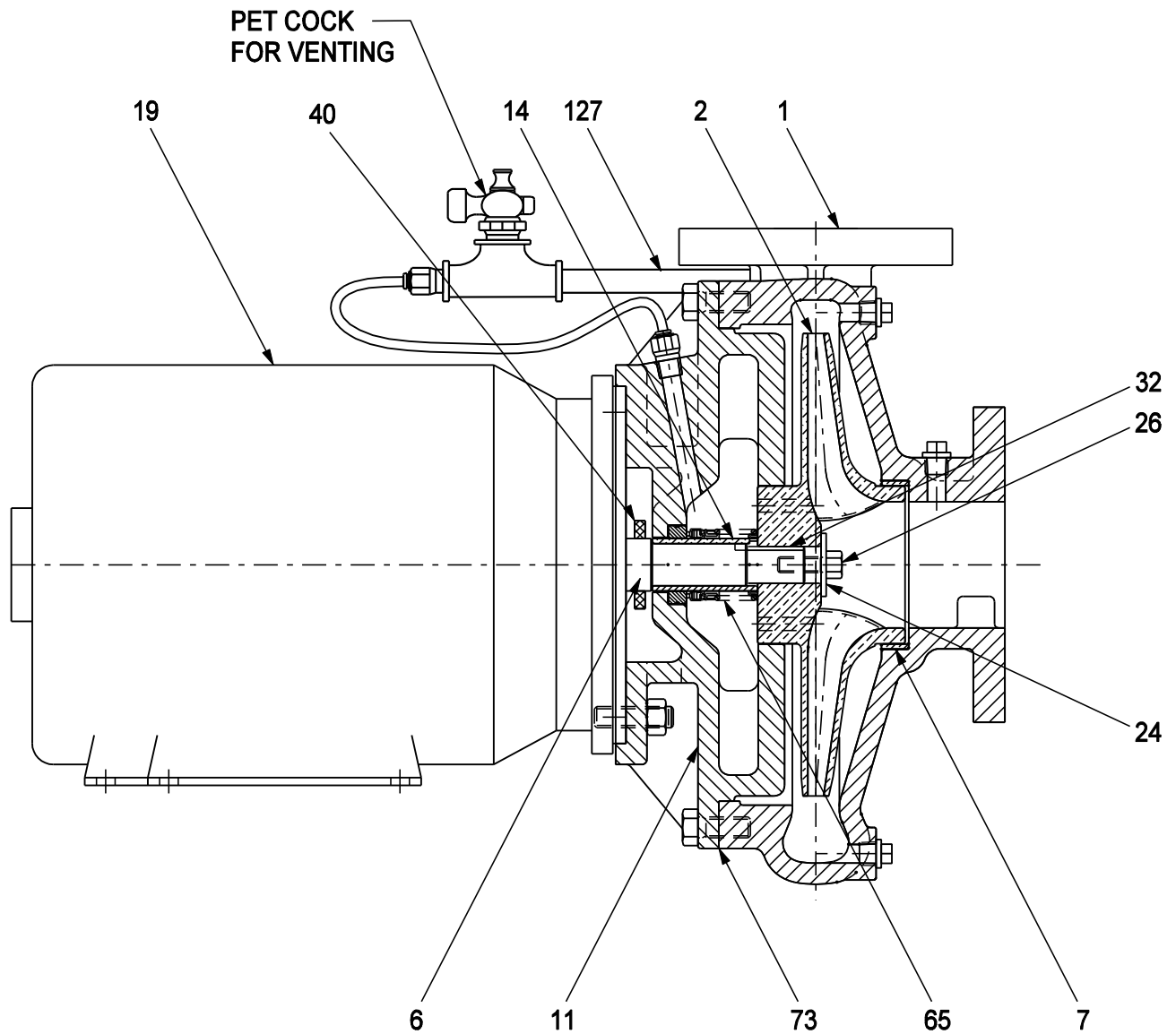

Typical Assembly Section, Type HVES-CC

ITEM	DESCRIPTION	MATERIAL	ITEM	DESCRIPTION	MATERIAL
1	CASING	Cast Iron - ASTM A48-CL30	24	IMPELLER WASHER	Stainless Steel
2	IMPELLER	Bronze - ASTM B584-875	26	IMPELLER SCREW	Stainless Steel - Type 304
6	MOTOR SHAFT	Alloy Steel - AISI 1045	32	IMPELLER KEY	Stainless Steel - ASTM Type 304
7	CASING RING	Bronze - ASTM B505-932	40	DEFLECTOR	Nitrile
11	VOLUTE COVER	Cast Iron - ASTM A48-CL30	65	MECHANICAL SEAL	316 S.S. / Carbon VS. Silicon Carbide
14	SHAFT SLEEVE	Bronze - ASTM B505-932	65	MECHANICAL SEAL (OPTIONAL)	316 S.S. / Tungsten Carbide VS. Tungsten Carbide
14	SHAFT SLEEVE (OPTIONAL)	416 S.S.	73	GASKET	Vellumoid
19	MOTOR	Manufacturer's Standard	127	SEAL PIPING	Polymer

Notes