

Multistage

Vertical Inline Pumps

PM1, PM3, PM5 Series



Patterson Pump Company

A Gorman-Rupp Company

2129 Ayersville Rd.

Toccoa, Georgia 30577

(706)886-2101/FAX:(706)886-0023

www.pattersonpumps.com

Please read and save this Repair Parts Manual. Read this manual and the General Operating Instructions carefully before attempting to assemble, install, operate or maintain the product described. Protect yourself and others by observing all safety information. The Safety Instructions are contained in the General Operating Instructions. Failure to comply with the safety instructions accompanying this product could result in personal injury and/or property damage! Retain instructions for future reference. AMT reserves the right to discontinue any model or change specifications at any time without incurring any obligation.

©2009 American Machine & Tool Co., Inc. of PA, A Subsidiary of The Gorman-Rupp Company, All Rights Reserved.

▲WARNING Periodic maintenance and inspection are required on all pumps to insure proper operation. Units must be free of debris and sediment. Inspect for leaks and loose bolts. Failure to do so voids warranty.

Multistage Centrifugal Pumps

Vertical Inline Models

Refer to form 1808-634-00 for General Operating and Safety Instructions

Description

APPLICATIONS

These commercial/industrial centrifugal pumps are non-self-priming (gravity feed) units designed to handle high-pressure/low-flow liquid transfer applications where no suction lift is required. Typical installations include hot and chilled water, boiler feed, condensate return, irrigation, high pressure wash-down, booster service, and sprinkler systems. These pumps have NOT been investigated for use in potable (drinking) water systems.

FEATURES

The in-line port design and compact footprint of these pumps allows for a clean installation. All models feature a shaft seal that can be replaced easily without the need to disassemble the entire pump. An optional ANSI/ASME flange kit is available. Pumps are equipped with high efficiency closed impellers, and have a casing working pressure to 536 ft./232 psi [1600 kPa]. Handle liquid temperatures from 40° F to 180° F [4° to 82° C]. For use with clear, nonabrasive, nonflammable liquids compatible with pump component materials.

MOTOR

All models have 3450 RPM continuous duty TEFC motors. Single phase units are capacitor start and have automatic reset thermal protection. All models are manual mode and require field wiring, no controls are supplied.

▲CAUTION Motors have multi-voltage options. To avoid damage to motor, be sure to arrange internal motor wiring to match electric supply voltage before applying power (see motor nameplate for specific wiring diagram).

PUMP CONSTRUCTION

Pump construction is cast iron casing and adapter; 304 stainless steel impellers, chambers and column; Teflon® wear rings; 304L stainless steel pump shaft with tungsten carbide sleeve bearings; EPDM o-rings and gaskets; a mechanical shaft seal of stainless steel, carbon graphite, and tungsten carbide wear faces.

Installation

MOUNTING

Preferred mounting position is with motor shaft aligned vertically (See Figure 1).

1. Choose a solid, level surface with adequate support such as a concrete slab floor.
2. Use a level against pump to check for plumb. For uneven surfaces, shim beneath feet of Casing (Ref. No. 38) to attain proper alignment.
3. Securely fasten Casing to mount surface at all four mount holes to avoid tip-over

of pump. If space limitations dictate, pump may also be mounted horizontally if adequate support is provided. Do NOT mount motor end down or with shaft centerline below horizontal plane.

PIPING

Pump may have a protective cover over inlet and outlet for shipping purposes. If present, be sure to remove these covers prior to attaching piping. If flange Screws (Ref. No. 41) are loosened, be sure to re-tighten evenly and torque to 33 ft-lbs [45 N-m] to avoid Gasket (Ref. No. 39) failure.

Starving the pump of liquid could cause low performance and damage to pump and seal. To avoid this, use suction piping that is short and either matches pump port diameter or is larger, do not reduce. Also, immediately preceding pump inlet, provide a section of straight pipe equal in length to a minimum 4 diameters of pipe size and avoid using valves.

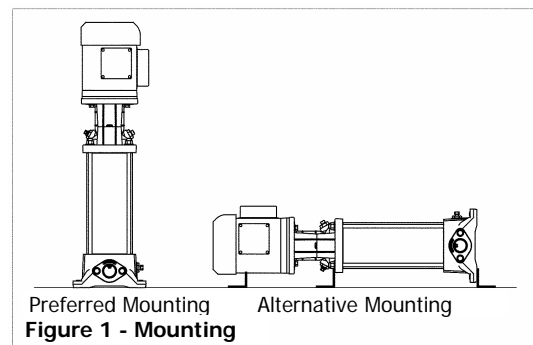

Preferred Mounting
Alternative Mounting
Figure 1 - Mounting

Multistage Centrifugal Pumps

Vertical Inline Models

Installation (Continued)

These pumps develop very high pressures. Be sure to confirm that pressure rating of all piping and fittings

is adequately sized before use. Rating must be sufficiently larger than the combination of both inlet pressure plus the maximum pressure pump can

develop.

▲ WARNING *Piping and/or pipe fittings with an insufficient pressure rating may burst and cause personal injury and/or property damage.*

MAXIMUM INLET PRESSURE

"1" Series

2 to 25 335 ft./145 psi [1000 kPa]
 27 stage 500 ft./217 psi [1500 kPa]

"3" Series

2 to 15 335 ft./145 psi [1000 kPa]
 17 to 25 500 ft./217 psi [1500 kPa]

"5" Series

2 to 9 335 ft./145 psi [1000 kPa]
 10 to 24 500 ft./217 psi [1500 kPa]

If system pressure has potential to exceed number listed above, then a check valve is required on discharge side of pump. This will ensure that proper inlet pressure is maintained when pump shuts off.

MAXIMUM OUTLET PRESSURE

If system pressure in excess of 536 ft./232 psi [1600 kPa] is possible, then it is necessary to provide means to prevent this. Examples include a bypass valve or pressure switch on discharge of pump set at or below this number.

Operation

Become familiar with pump components (See Figure 3).

Vent Plug (Ref. No. 13) – Used to purge air from pump.

Wash Plug (Ref. No. 11) – Used in applications where seal wash is desired to extend life of shaft seal.

Bypass Valve (Ref. No. 42) – Connects suction and discharge sides of pump, making filling/draining procedure easier. During operation, bypass valve must be closed.

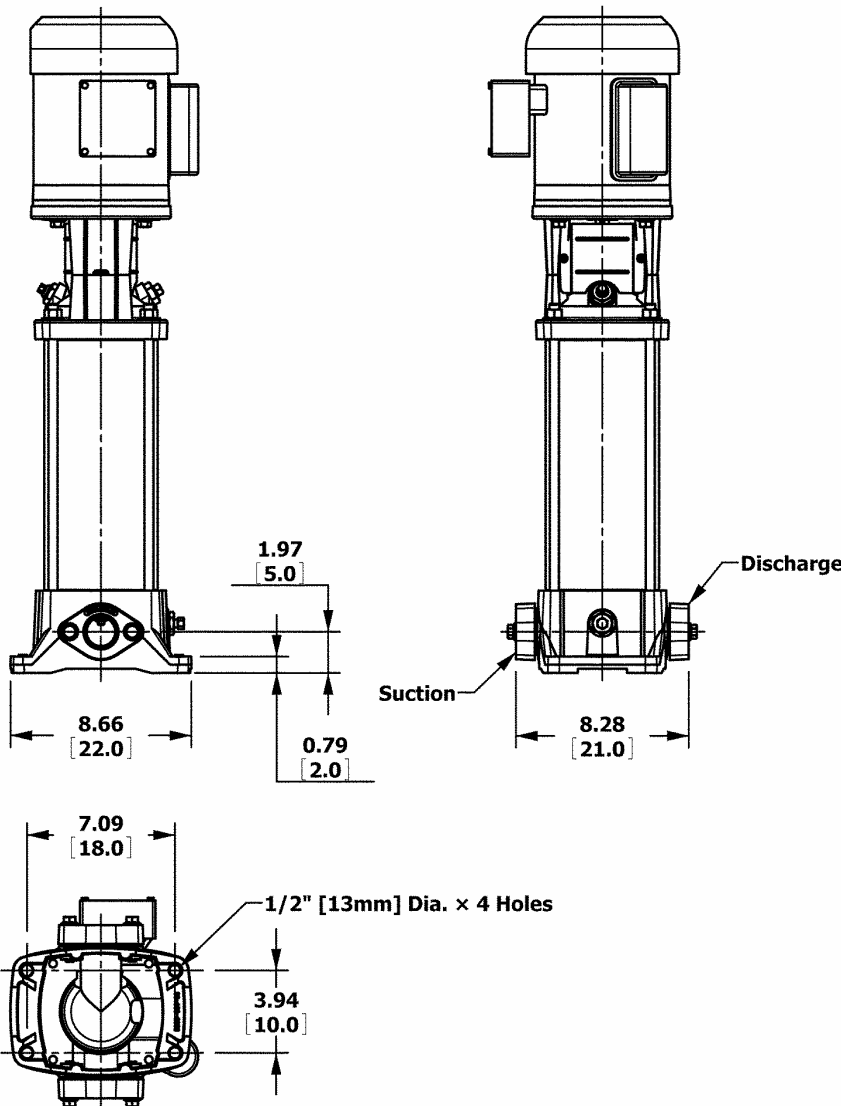

Figure 2 - Dimensions

Dimensions Inches [cm]

| Model | Suction* | Discharge* | HP | Nominal Flow |
|------------|------------|------------|--------------|------------------|
| "1" Series | 1" NPT | 1" NPT | 1/2 thru 3 | 8 gpm [30 lpm] |
| "3" Series | 1" NPT | 1" NPT | 1 thru 5 | 16 gpm [61 lpm] |
| "5" Series | 1 1/4" NPT | 1 1/4" NPT | 2 thru 7 1/2 | 30 gpm [114 lpm] |

NOTE: All dimensions have a tolerance of ±1/8" [0.3].

(*) Standard NPT (female) pipe thread.

Models PM1, PM3, and PM5

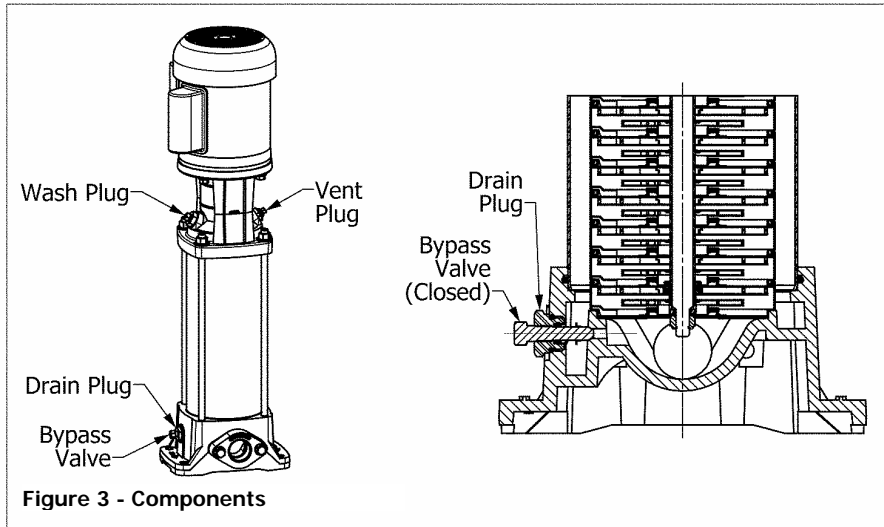

Figure 3 - Components

Operation (Continued)

CAUTION *Never run pump dry or with flow shutoff. When pump is running, always maintain a minimum flow of 4 gpm [0.9 m³/h] to avoid damage to pump.*

STARTUP PROCEDURE

CAUTION *To avoid pump damage, it is very important to purge all air from pump before initial startup.*

1. Close discharge valve if present.
2. Permit liquid to flow into pump thru suction port by gravity.
3. Allow air to escape from pump by cracking open Vent Plug (Ref. No. 13) in top of pump housing near motor.
4. Wait for liquid to cease sputtering. When liquid flow changes to a steady stream with no air, close Vent Plug.
5. Run pump briefly, then repeat steps 1 thru 4 repeatedly until all air is evacuated. Pump is now ready to be run.

ROTATION

Proper rotation is CLOCKWISE when looking up at shaft end of motor, see

directional arrow cast into motor Adapter (Ref. No. 8). Bump motor on/off briefly to confirm motor is wired for correct rotation. Disregard rotation information found elsewhere in safety manual.

DRAINING

1. Remove Bypass Valve (Ref. No. 42) and Vent Plug (Ref. No. 13) completely.
2. Allow liquid to drain.
3. If pump is to be subjected to freezing temperatures, do not reinstall Valve/Plug.

CYCLING

Frequent on/off cycling can shorten motor life. System should be designed so that pump is NOT starting more than 15 times per hour.

Maintenance

WARNING *Make certain that unit is disconnected from power source before attempting to service or remove any components!*

MOTOR REPLACEMENT

DISASSEMBLY

Refer to Figure 8

1. Remove two coupling Shields (Ref.

No. 9) by unscrewing two Fasteners (Ref. No. 10) for each.

2. Loosen four Fasteners (Ref. No. 4) in Coupling (Ref. No. 3) evenly until Motor shaft (Ref. No. 1) can turn independently from Coupling.
3. Remove four Fasteners (Ref. No. 14) from Adapter (Ref. No 8). Motor is now free, lift straight up to remove from unit.

REASSEMBLY

1. Remove key (if present) from new Motor shaft and discard.
2. Wipe any protective film from Motor end bell and shaft, be sure they are clean.
3. Carefully guide Motor shaft into Coupling while setting new Motor into place.
4. Reinstall four Fasteners thru Adapter. Tighten evenly and in diagonal pattern, then torque to the following specifications:

| | |
|-----------|---------------------|
| 3/8 | 17 ft-lbs. [23 N-m] |
| 1/2 | 30 ft-lbs. [41 N-m] |

5. Locate shaft keyway in center of Coupling (See Figure 4) and maintain this position, then snug up Fasteners evenly. Check gap between coupling halves to be sure it remains even on both sides. Torque Fasteners to the following specifications.

| | |
|----------|---------------------|
| M6 | 10 ft-lbs. [14 N-m] |
| M8 | 23 ft-lbs. [31 N-m] |
| M10..... | 46 ft-lbs. [62 N-m] |

6. Rotate pump Shaft by hand. If binding or rubbing is found, loosen Coupling and readjust position.
7. Reattach Shields and proceed to Startup Procedure section.

SHAFT SEAL REPLACEMENT

DISASSEMBLY

Refer to Figure 8.

1. Remove Motor (see Motor Replacement section).

Multistage Centrifugal Pumps

Vertical Inline Models

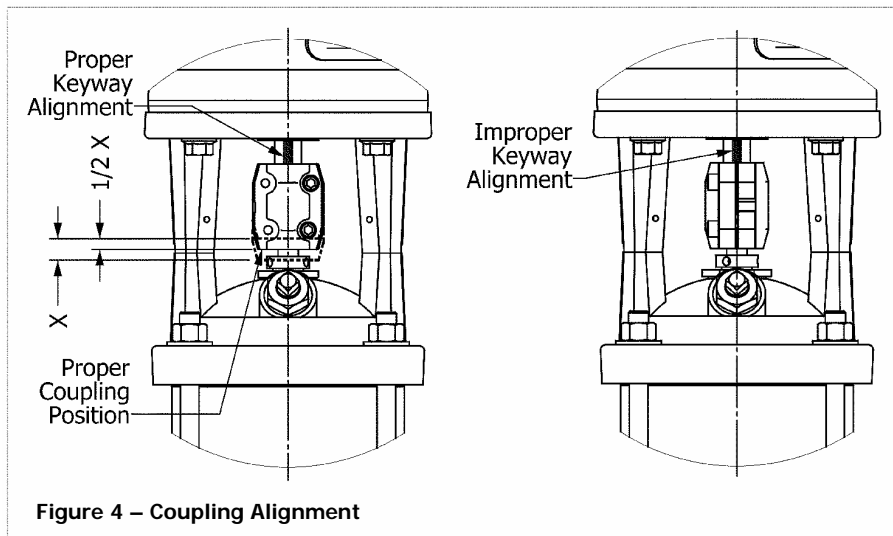

Figure 4 – Coupling Alignment

Maintenance (Continued)

- Remove Coupling (Ref. No. 3) and Rod (Ref. No. 2) by unthreading Screws (Ref. No. 4).
- Loosen, but do not remove set screws in Shaft Seal Assembly (Ref. No. 7).
- Unscrew Shaft Seal Assembly in a counter-clockwise direction, then carefully lift off of Shaft (Ref. No. 21).

REASSEMBLY

IMPORTANT: Pump Shaft may have been gouged from set screws. Before installing new Shaft Seal Assembly, smooth-over these gouges with a light grit emery cloth to prevent damage to new seal.

- Once shaft is free of burrs, lubricate Shaft and o-ring cavity in Adapter (Ref. No. 8) with soapy water.
- Carefully slide new Shaft Seal Assembly onto Shaft, then tighten in clockwise direction and torque to 26 ft-lbs [35 N-m].
- Mark or otherwise note shaft height. Lift shaft as high as it will go, then lower it back down $\frac{1}{2}$ the total distance. Maintain this position

while evenly tightening 3 set screws in seal collar and torque each to 2 ft-lbs. [2.5 N-m].

- Place Rod thru Shaft, then reinstall Coupling and screws but do NOT tighten.
- Proceed to Reassembly under Motor Replacement section.

PUMP OVERHAUL/INSPECTION

To inspect condition of pump internals, proceed as follows:

NOTE: To facilitate overhaul, a handy

holding device can be made easily. Take a short piece of 2×4 lumber and on the narrow side, drill a 1/2" diameter blind hole 3" deep. Place block into bench vice with hole facing up to receive pump shaft after step 5 (see Figure 5).

DISASSEMBLY

- Proceed to Disassembly under Shaft Seal Replacement.
- Remove 4 Fastener sets (Ref. Nos. 15 & 16).
- Lift Adapter (Ref. No. 8) from pump, use a soft mallet to break loose if necessary.

NOTE: Inspect o-ring groove in Adapter after o-ring is removed. Rust/pitting in this region may cause leaks, be sure to clean or replace Adapter entirely if damage is excessive.

- Remove wave Spring (Ref. No. 18) from Adapter.

NOTE: Inspect wave Spring for cracks and replace if found.

- Pump internals can now be removed all at once. Use pump Shaft (Ref. No. 21) as a handle and gently lift the entire assembly out. If stage-1 Volute (Ref. No. 38) stays behind, it can be removed and inspected later.

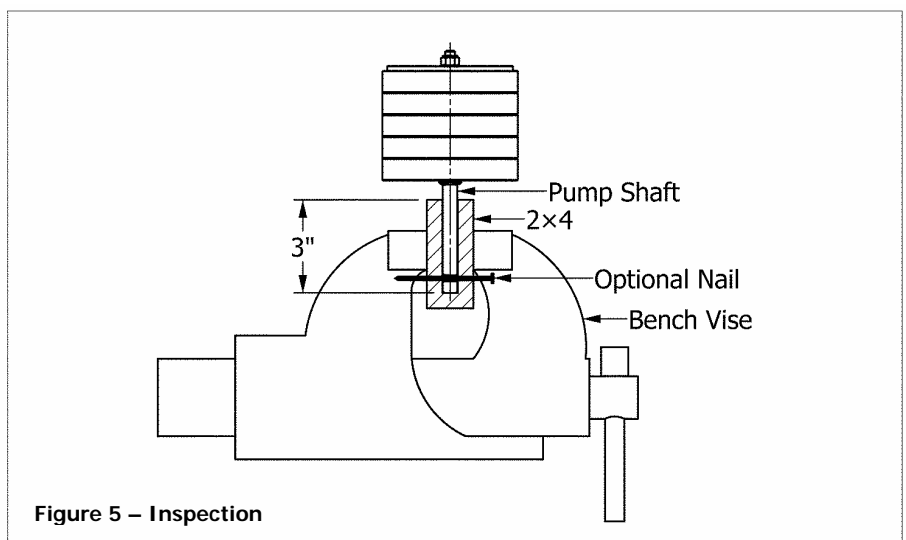

Figure 5 – Inspection

For Repair Parts, contact dealer where pump was purchased

Please provide the following information:

- Model number
- Serial number (if any)
- Part description and number as shown in parts list

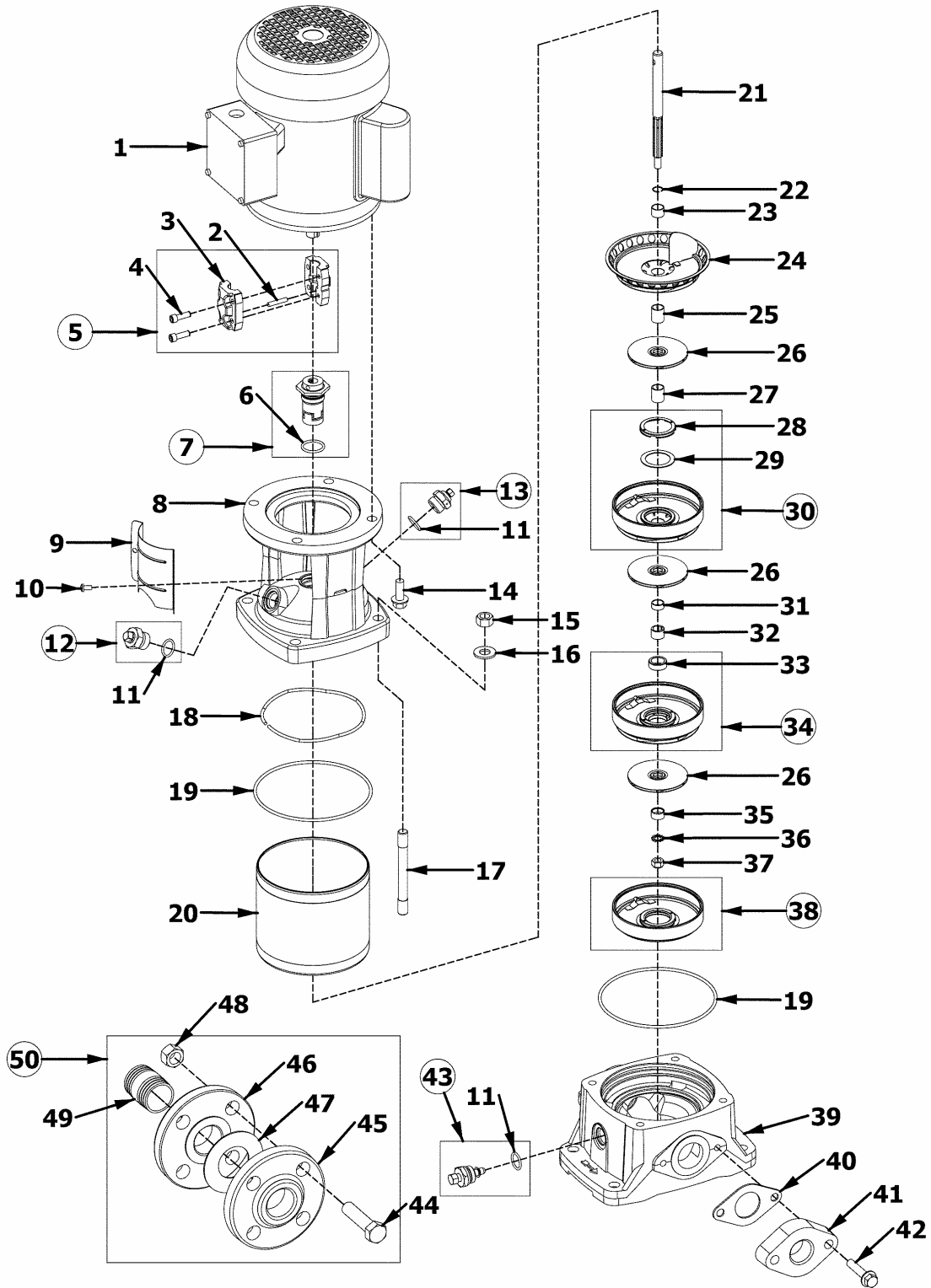

Figure 8 – Repair Parts Illustration

Repair Parts List

| Ref. No. | Description | Part Number for Models: | | | Qty. |
|----------|---|-------------------------|---------------|---------------|--------|
| | | "1" Series | "3" Series | "5" Series | |
| 1 | Motor | see page 9 | see page 9 | see page 10 | 1 |
| 2 | Rod | 5900-072-00 | 5900-072-00 | 5900-072-00 | 1 |
| 3 | Coupling | 5900-070-00 | 5920-070-00 | 5930-070-00 | 2 |
| 4 | Socket Head Cap Screw - ISO Class 12.9 | * M6-1×20 | * M8-1.25×25 | * M10-1.5×25 | 4 |
| 5 | Coupling Kit (Includes Ref. Nos. 2, 3, 4) | 5900-070-90 | 5920-070-90 | 5930-070-90 | 1 |
| 6 | O-ring - EPDM | * M2.65×22.4 | * M2.65×22.4 | * M2.65×22.4 | 1 |
| 7 | Shaft Seal - EPDM, Carbon, Tungsten Carbide (Includes Ref. No. 6) | 5900-300-00 | 5900-300-00 | 5900-300-00 | 1 |
| 8 | Adapter | see page 9 | see page 9 | see page 10 | 1 |
| 9 | Shield | see page 9 | see page 9 | see page 10 | 2 |
| 10 | Pan Head Machine Screw | * M4-0.7×8 | * M4-0.7×8 | * M4-0.7×8 | 4 |
| 11 | O-ring - EPDM | * M2.4×17.8 | * M2.4×17.8 | * M2.4×17.8 | 3 |
| 12 | Wash Plug Assembly (Includes Ref. No. 11) | 5900-044-90 | 5900-044-90 | 5900-044-90 | 1 |
| 13 | Vent Plug Assembly (Includes Ref. No. 11) | 5900-044-90 | 5900-044-90 | 5900-044-90 | 1 |
| 14 | Hex Head Cap Screw - SAE Grade 5 | * see page 9 | * see page 9 | * see page 10 | 4 |
| 15 | Hex Nut - ASTM Class A2-70 | * M12-1.75 | * M12-1.75 | * M12-1.75 | 4 |
| 16 | Flat Washer - SS | * M12 | * M12 | * M12 | 4 |
| 17 | Staybolt (multiple lengths) | see page 9 | see page 9 | see page 10 | 4 |
| 18 | Spring | 5900-036-00 | 5900-036-00 | 5900-036-00 | 1 |
| 19 | O-ring - EPDM | * M3.5×138 | * M3.5×138 | * M3.5×138 | 2 |
| 20 | Cylinder (multiple lengths) | see page 9 | see page 9 | see page 10 | 1 |
| 21 | Shaft (multiple lengths) | see page 9 | see page 9 | see page 10 | 1 |
| 22 | Retaining Ring | 5900-090-00 | 5900-090-00 | 5900-090-00 | 1 |
| 23 | Collar | 5900-086-00 | 5900-086-00 | 5900-086-00 | 1 |
| 24 | Top Plate Weldment w/Crossover (Standard) | 5900-172-00 | 5900-172-00 | 5930-172-00 | 1 |
| 24a | Top Plate Weldment (2-Stage Models Only) | 5900-170-00 | 5900-170-00 | N/A | 1 |
| 25 | Sleeve 18.0mm (2-Stage Models Only) | 5900-094-00 | 5900-094-00 | N/A | 1 |
| 26 | Impeller Weldment | 5900-010-00 | 5920-010-00 | 5930-010-00 | Varies |
| 27 | Sleeve 17.5/26.0mm (Standard) | 5900-080-00 | 5900-080-00 | 5900-080-00 | Varies |
| 28 | Cap | 5900-156-00 | 5900-156-00 | 5930-156-00 | Varies |
| 29 | Wear Ring - Teflon® | 5900-084-00 | 5900-084-00 | 5930-084-00 | Varies |
| 30 | Crossover Weldment (Includes 28, 29) | 5900-160-00 | 5900-160-00 | 5930-160-00 | Varies |
| 31 | Sleeve 6.5/15.0mm (Bearing Companion) | 5900-078-00 | 5900-078-00 | 5930-088-00 | Varies |
| 32 | Bearing Inner - Tungsten Carbide | 5900-082-00 | 5900-082-00 | 5900-082-00 | Varies |
| 33 | Bearing Outer - Tungsten Carbide | 5900-083-00 | 5900-083-00 | 5900-083-00 | Varies |
| 34 | Crossover Weldment w/Bearing (Includes 28, 29, 33) | 5900-162-00 | 5900-162-00 | 5930-162-00 | Varies |
| 35 | Sleeve Cup | 5900-076-00 | 5900-076-00 | 5900-076-00 | 1 |
| 36 | Star Washer | * M8 | * M8 | * M8 | 1 |
| 37 | Hex Nut w/Nyloc | * M8-1.25 | * M8-1.25 | * M8-1.25 | 1 |
| 38 | Volute Weldment (Includes 28, 29) | 5900-150-00 | 5900-150-00 | 5930-150-00 | Varies |
| 39 | Casing | 5900-001-00 | 5900-001-00 | 5900-001-00 | 1 |
| 40 | Oval Gasket - EPDM | 5900-053-00 | 5900-053-00 | 5900-053-00 | 2 |
| 41 | NPT Flange | 5900-050-01 | 5900-050-01 | 5900-050-02 | 2 |
| 42 | Hex Head Cap Screw - Class A2-70 | * M10-1.50×40 | * M10-1.50×40 | * M10-1.50×40 | 4 |
| 43 | Vent Plug Assembly (Includes Ref. No. 11) | 5900-048-90 | 5900-048-90 | 5900-048-90 | 1 |
| 44 | Hex Head Cap Screw | * 5/8"UNC×2½" | * 5/8"UNC×2½" | * 5/8"UNC×2½" | 8 |
| 45 | Pipe Flange - ANSI/ASME 250# (Outer) | * 1¼" NPT | * 1¼" NPT | * 1¼" NPT | 2 |
| 46 | Pipe Flange - ANSI/ASME 250# (Inner) | * 1" NPT | * 1" NPT | * 1¼" NPT | 2 |
| 47 | Gasket | 5900-068-00 | 5900-068-00 | 5900-068-00 | 2 |
| 48 | Hex Nut | * 5/8"-18UNC | * 5/8"-18UNC | * 5/8"-18UNC | 8 |
| 49 | Pipe Nipple | * 1" NPT | * 1" NPT | * 1¼" NPT | 2 |
| 50 | Pipe Flange Kit - ANSI/ASME 250# (Includes one each: 45, 46, 47, 49; and four each: 44, 48) | 5900-064-90 | 5900-064-90 | 5900-064-91 | 2 |
| † | Seal Kit - Complete (Includes Ref. Nos. 7, 11, 19, 40) | 5900-300-90 | 5900-300-90 | 5900-300-90 | 1 |

(*) Standard hardware item, available locally.

(†) Not Shown

(N/A) Not Applicable

Repair Parts List (Continued)

| Model | HP | Ref. No. 1 1 Phase | Motor 3 Phase | Ref. No. 8 Adapter | Ref. No. 9 Shield | Ref. No. 14 Cap Screw | Ref. No. 17 Staybolt | Ref. No. 20 Cylinder | Ref. No. 21 Shaft |
|-------------------|-----|-----------------------|------------------|-----------------------|----------------------|--------------------------|-------------------------|-------------------------|----------------------|
| "1" Series | | | | | | | | | |
| 2-Stage | 1/2 | 1626-320-00 | 1626-326-00 | 5900-030-00 | 5900-038-00 | 3/8"-16UNC×1¼" | 5900-702-00 | 5900-602-00 | 5900-503-00 |
| 3-Stage | 1/2 | 1626-320-00 | 1626-326-00 | 5900-030-00 | 5900-038-00 | 3/8"-16UNC×1¼" | 5900-702-00 | 5900-602-00 | 5900-503-00 |
| 4-Stage | 1/2 | 1626-320-00 | 1626-326-00 | 5900-030-00 | 5900-038-00 | 3/8"-16UNC×1¼" | 5900-704-00 | 5900-604-00 | 5900-504-00 |
| 5-Stage | 1/2 | 1626-320-00 | 1626-326-00 | 5900-030-00 | 5900-038-00 | 3/8"-16UNC×1¼" | 5900-705-00 | 5900-605-00 | 5900-505-00 |
| 6-Stage | 3/4 | 1626-321-00 | 1626-327-00 | 5900-030-00 | 5900-038-00 | 3/8"-16UNC×1¼" | 5900-706-00 | 5900-606-00 | 5900-506-00 |
| 7-Stage | 3/4 | 1626-321-00 | 1626-327-00 | 5900-030-00 | 5900-038-00 | 3/8"-16UNC×1¼" | 5900-707-00 | 5900-607-00 | 5900-507-00 |
| 8-Stage | 1 | 1626-322-00 | 1626-328-00 | 5900-030-00 | 5900-038-00 | 3/8"-16UNC×1¼" | 5900-708-00 | 5900-608-00 | 5900-508-00 |
| 9-Stage | 1 | 1626-322-00 | 1626-328-00 | 5900-030-00 | 5900-038-00 | 3/8"-16UNC×1¼" | 5900-709-00 | 5900-609-00 | 5900-509-00 |
| 10-Stage | 1 | 1626-322-00 | 1626-328-00 | 5900-030-00 | 5900-038-00 | 3/8"-16UNC×1¼" | 5900-710-00 | 5900-610-00 | 5900-510-00 |
| 11-Stage | 1½ | 1626-323-00 | 1626-329-00 | 5900-030-00 | 5900-038-00 | 3/8"-16UNC×1¼" | 5900-711-00 | 5900-611-00 | 5900-511-00 |
| 12-Stage | 1½ | 1626-323-00 | 1626-329-00 | 5900-030-00 | 5900-038-00 | 3/8"-16UNC×1¼" | 5900-712-00 | 5900-612-00 | 5900-512-00 |
| 13-Stage | 1½ | 1626-323-00 | 1626-329-00 | 5900-030-00 | 5900-038-00 | 3/8"-16UNC×1¼" | 5900-713-00 | 5900-613-00 | 5900-513-00 |
| 15-Stage | 2 | 1626-324-00 | 1626-330-00 | 5900-030-00 | 5900-038-00 | 3/8"-16UNC×1¼" | 5900-715-00 | 5900-615-00 | 5900-515-00 |
| 17-Stage | 2 | 1626-324-00 | 1626-330-00 | 5900-030-00 | 5900-038-00 | 3/8"-16UNC×1¼" | 5900-717-00 | 5900-617-00 | 5900-517-00 |
| 19-Stage | 2 | 1626-324-00 | 1626-330-00 | 5900-030-00 | 5900-038-00 | 3/8"-16UNC×1¼" | 5900-719-00 | 5900-619-00 | 5900-519-00 |
| 21-Stage | 3 | 1626-325-00 | 1626-331-00 | 5900-030-00 | 5900-038-00 | 3/8"-16UNC×1¼" | 5900-721-00 | 5900-621-00 | 5900-521-00 |
| 23-Stage | 3 | 1626-325-00 | 1626-331-00 | 5900-030-00 | 5900-038-00 | 3/8"-16UNC×1¼" | 5900-725-00 | 5900-623-00 | 5900-523-00 |
| 25-Stage | 3 | 1626-325-00 | 1626-331-00 | 5900-030-00 | 5900-038-00 | 3/8"-16UNC×1¼" | 5900-725-00 | 5900-625-00 | 5900-525-00 |
| 27-Stage | 3 | 1626-325-00 | 1626-331-00 | 5900-030-00 | 5900-038-00 | 3/8"-16UNC×1¼" | 5900-727-00 | 5900-627-00 | 5900-527-00 |
| "3" Series | | | | | | | | | |
| 2-Stage | 1 | 1626-322-00 | 1626-328-00 | 5900-030-00 | 5900-038-00 | 3/8"-16UNC×1¼" | 5900-702-00 | 5900-602-00 | 5900-503-00 |
| 3-Stage | 1 | 1626-322-00 | 1626-328-00 | 5900-030-00 | 5900-038-00 | 3/8"-16UNC×1¼" | 5900-702-00 | 5900-602-00 | 5900-503-00 |
| 4-Stage | 1 | 1626-322-00 | 1626-328-00 | 5900-030-00 | 5900-038-00 | 3/8"-16UNC×1¼" | 5900-704-00 | 5900-604-00 | 5900-504-00 |
| 5-Stage | 1 | 1626-322-00 | 1626-328-00 | 5900-030-00 | 5900-038-00 | 3/8"-16UNC×1¼" | 5900-705-00 | 5900-605-00 | 5900-505-00 |
| 6-Stage | 1 | 1626-322-00 | 1626-328-00 | 5900-030-00 | 5900-038-00 | 3/8"-16UNC×1¼" | 5900-706-00 | 5900-606-00 | 5900-506-00 |
| 7-Stage | 1½ | 1626-323-00 | 1626-329-00 | 5900-030-00 | 5900-038-00 | 3/8"-16UNC×1¼" | 5900-707-00 | 5900-607-00 | 5900-507-00 |
| 8-Stage | 1½ | 1626-323-00 | 1626-329-00 | 5900-030-00 | 5900-038-00 | 3/8"-16UNC×1¼" | 5900-708-00 | 5900-608-00 | 5900-508-00 |
| 9-Stage | 1½ | 1626-323-00 | 1626-329-00 | 5900-030-00 | 5900-038-00 | 3/8"-16UNC×1¼" | 5900-709-00 | 5900-609-00 | 5900-509-00 |
| 10-Stage | 2 | 1626-324-00 | 1626-330-00 | 5900-030-00 | 5900-038-00 | 3/8"-16UNC×1¼" | 5900-710-00 | 5900-610-00 | 5900-510-00 |
| 11-Stage | 2 | 1626-324-00 | 1626-330-00 | 5900-030-00 | 5900-038-00 | 3/8"-16UNC×1¼" | 5900-711-00 | 5900-611-00 | 5900-511-00 |
| 12-Stage | 2 | 1626-324-00 | 1626-330-00 | 5900-030-00 | 5900-038-00 | 3/8"-16UNC×1¼" | 5900-712-00 | 5900-612-00 | 5900-512-00 |
| 13-Stage | 3 | 1626-325-00 | 1626-331-00 | 5900-030-00 | 5900-038-00 | 3/8"-16UNC×1¼" | 5900-713-00 | 5900-613-00 | 5900-513-00 |
| 15-Stage | 3 | 1626-325-00 | 1626-331-00 | 5900-030-00 | 5900-038-00 | 3/8"-16UNC×1¼" | 5900-715-00 | 5900-615-00 | 5900-515-00 |
| 17-Stage | 3 | 1626-325-00 | 1626-331-00 | 5900-030-00 | 5900-038-00 | 3/8"-16UNC×1¼" | 5900-717-00 | 5900-617-00 | 5900-517-00 |
| 19-Stage | 3 | 1626-325-00 | 1626-331-00 | 5900-030-00 | 5900-038-00 | 3/8"-16UNC×1¼" | 5900-719-00 | 5900-619-00 | 5900-519-00 |
| 21-Stage | 5 | N/A | 1626-360-00 | 5920-030-00 | 5920-038-00 | 1/2"-13UNC×1¼" | 5900-721-00 | 5900-621-00 | 5900-521-00 |
| 23-Stage | 5 | N/A | 1626-360-00 | 5920-030-00 | 5920-038-00 | 1/2"-13UNC×1¼" | 5900-725-00 | 5900-623-00 | 5900-523-00 |
| 25-Stage | 5 | N/A | 1626-360-00 | 5920-030-00 | 5920-038-00 | 1/2"-13UNC×1¼" | 5900-725-00 | 5900-625-00 | 5900-525-00 |

Repair Parts List (Continued)

| Model | HP | Ref. No. 1 1 Phase | Motor 3 Phase | Ref. No. 8 Adapter | Ref. No. 9 Shield | Ref. No. 14 Cap Screw | Ref. No. 17 Staybolt | Ref. No. 20 Cylinder | Ref. No. 21 Shaft |
|-------------------|----|-----------------------|------------------|-----------------------|----------------------|--------------------------|-------------------------|-------------------------|----------------------|
| "5" Series | | | | | | | | | |
| 2-Stage | 2 | 1626-324-00 | 1626-330-00 | 5900-030-00 | 5900-038-00 | 3/8"-16UNCx1" | 5900-702-00 | 5900-602-00 | 5930-503-00 |
| 3-Stage | 2 | 1626-324-00 | 1626-330-00 | 5900-030-00 | 5900-038-00 | 3/8"-16UNCx1" | 5930-703-00 | 5930-603-00 | 5930-503-00 |
| 4-Stage | 2 | 1626-324-00 | 1626-330-00 | 5900-030-00 | 5900-038-00 | 3/8"-16UNCx1" | 5900-706-00 | 5900-606-00 | 5930-504-00 |
| 5-Stage | 2 | 1626-324-00 | 1626-330-00 | 5900-030-00 | 5900-038-00 | 3/8"-16UNCx1" | 5930-705-00 | 5930-605-00 | 5930-505-00 |
| 6-Stage | 2 | 1626-324-00 | 1626-330-00 | 5900-030-00 | 5900-038-00 | 3/8"-16UNCx1" | 5900-709-00 | 5900-609-00 | 5930-506-00 |
| 7-Stage | 2 | 1626-324-00 | 1626-330-00 | 5900-030-00 | 5900-038-00 | 3/8"-16UNCx1" | 5930-707-00 | 5930-607-00 | 5930-507-00 |
| 8-Stage | 3 | 1626-325-00 | 1626-331-00 | 5900-030-00 | 5900-038-00 | 3/8"-16UNCx1" | 5900-712-00 | 5900-612-00 | 5930-508-00 |
| 9-Stage | 3 | 1626-325-00 | 1626-331-00 | 5900-030-00 | 5900-038-00 | 3/8"-16UNCx1" | 5930-709-00 | 5930-609-00 | 5930-509-00 |
| 10-Stage | 3 | 1626-325-00 | 1626-331-00 | 5900-030-00 | 5900-038-00 | 3/8"-16UNCx1" | 5900-715-00 | 5900-615-00 | 5930-510-00 |
| 11-Stage | 5 | N/A | 1626-360-00 | 5920-030-00 | 5920-038-00 | 1/2"-13UNCx1¼" | 5930-711-00 | 5930-611-00 | 5930-511-00 |
| 12-Stage | 5 | N/A | 1626-360-00 | 5920-030-00 | 5920-038-00 | 1/2"-13UNCx1¼" | 5930-712-00 | 5930-612-00 | 5930-512-00 |
| 13-Stage | 5 | N/A | 1626-360-00 | 5920-030-00 | 5920-038-00 | 1/2"-13UNCx1¼" | 5930-713-00 | 5930-613-00 | 5930-513-00 |
| 14-Stage | 5 | N/A | 1626-360-00 | 5920-030-00 | 5920-038-00 | 1/2"-13UNCx1¼" | 5900-721-00 | 5900-621-00 | 5930-514-00 |
| 15-Stage | 5 | N/A | 1626-360-00 | 5920-030-00 | 5920-038-00 | 1/2"-13UNCx1¼" | 5930-715-00 | 5930-615-00 | 5930-515-00 |
| 16-Stage | 5 | N/A | 1626-360-00 | 5920-030-00 | 5920-038-00 | 1/2"-13UNCx1¼" | 5930-716-00 | 5930-616-00 | 5930-516-00 |
| 18-Stage | 7½ | N/A | 1626-361-00 | 5920-030-00† | 5920-038-00 | 1/2"-13UNCx1¼" | 5900-727-00 | 5900-627-00 | 5930-518-00 |
| 20-Stage | 7½ | N/A | 1626-361-00 | 5920-030-00† | 5920-038-00 | 1/2"-13UNCx1¼" | 5930-720-00 | 5930-620-00 | 5930-520-00 |
| 22-Stage | 7½ | N/A | 1626-361-00 | 5920-030-00† | 5920-038-00 | 1/2"-13UNCx1¼" | 5930-722-00 | 5930-622-00 | 5930-522-00 |
| 24-Stage | 7½ | N/A | 1626-361-00 | 5920-030-00† | 5920-038-00 | 1/2"-13UNCx1¼" | 5930-724-00 | 5930-624-00 | 5930-524-00 |

(†) Adapter requires Disk 5930-035-00

Models PM1, PM3, and PM5

Maintenance (Continued)

IMPORTANT: Stainless steel components deform easily, be careful to avoid damaging pump components during disassembly.

6. Unscrew Hex Nut (Ref. No. 37) from pump Shaft in a counter-clockwise direction and remove along with Sleeve Cup (Ref. No. 35).
7. Lift Volute (if still present) and Impeller (Ref. No. 26) from stack and set aside.

IMPORTANT: Take note of sequence parts are arranged in and direction they are facing, number and mark if necessary (see Figure 6 & 7).

8. Lift next Volute/Crossover (Ref. No. 34), Inner Bearing (Ref. No. 32), and Impeller from stack.

NOTE: Inspect Inner and Outer Bearings for wear. If grooves can be seen or felt, replace both bearings as a set.

9. Use a large straight blade screwdriver to carefully pry Cap (Ref. No. 28) from Crossover to free Wear Ring (Ref. No. 29).

NOTE: Inspect for wear by placing Wear Ring over nose of Impeller and noting clearance between two diameters. If fit is not snug, replace Wear Ring.

10. Repeat Steps 7 and 8 for each stage (some stages have no bearings).

NOTE: Inspect Shaft (Ref. No. 21) for grooves, replace if splines are worn.

11. Lift Cylinder (Ref. No. 20) from Casing (Ref. No. 39), use a soft

mallet to break loose if necessary.

NOTE: Inspect o-ring groove in Casing after o-ring is removed. Rust/pitting in this region may cause leaks, be sure to clean or replace Casing entirely if damage is excessive.

12. If stage-1 Volute (Ref. No. 38) remains in Casing, now is the time to remove it. Gently pry loose with a straight blade screwdriver, being careful to avoid bending it.
13. Unscrew 2 fasteners (Ref. No. 42).
14. Use a straight blade screwdriver to pry pipe Flange (Ref. No. 41) loose.
15. Use a putty knife to scrape off old Gasket (Ref. No. 40) from Flange and Casing.

REASSEMBLY

1. Always use new Gaskets (Ref. No. 40) when reassembling. Attach pipe Flanges (Ref. No. 41) with Fasteners (Ref. No. 42). Tighten evenly and torque to 33 ft-lbs [45 N-m].
2. Place new O-ring (Ref. No. 19) into cleaned groove of Casing (Ref. No. 39), be sure to lubricate with soapy water or suitable material.
3. Place stage-1 Volute (Ref. No. 38) back into Casing (Ref. No. 39) making sure it is seated properly.
4. Carefully guide Cylinder (Ref. No. 20) back into Casing and press down.

IMPORTANT: If Cylinder does not fully seat, O-ring may be pinched. If this occurs, lift Cylinder back out and try stretching O-ring. Be sure components

are adequately lubricated and have not been damaged. Repeat process until end of Cylinder bottoms on Casing.

5. Reassemble Impellers (Ref. No. 26), Crossovers (Ref. No. 34), etc. onto pump Shaft (Ref. No. 21) in same order they were removed (see Figure 6 & 7) and torque Hex Nut w/Nyloc (Ref. No. 37) to 13 ft-lbs [18 N-m].

IMPORTANT: NEVER reuse Hex Nut w/Nyloc, ALWAYS replace with new unused one.

6. Take Impeller/Crossover stack by Shaft and lower into pump until properly seated.
7. Place new O-ring (Ref. No. 19) into cleaned groove of Adapter (Ref. No. 8), be sure to lubricate with soapy water or suitable material.
8. Install wave Spring (Ref. No. 18) with ends pointed towards Adapter. With wave Spring seated on proper landing in Adapter, carefully guide Adapter onto pump and press down.

IMPORTANT: If Adapter does not fully seat, O-ring may be pinched. If this occurs, lift Cylinder back out and try stretching O-ring. Be sure components are adequately lubricated and have not been damaged. Repeat process until Adapter bottoms on end of Cylinder.

9. Reinstall Fasteners (Ref. Nos. 15 & 16) onto Staybolts (Ref. No. 17) and tighten diagonally.
10. Proceed to Reassembly portion of Shaft Seal Replacement.