

# PATTERSON PUMP COMPANY

A Subsidiary of the Gorman Rupp Company



## JOCKEY PUMP CONTROLLERS

UL508 LISTED

ETL LISTED

FEBRUARY 2008

Patterson Jockey Pump controllers are built to NEMA industrial standards and are UL508 listed and ETL Certified. These controllers are intended for use with fire pump systems.

Jockey pumps are small, motor driven pumps used in conjunction with main fire pumps to compensate for minor leaks in the fire protection system and automatically maintain stand-by pressure. This reduces wear on the main pump and controller caused by unnecessary, frequent operation.

Jockey Pump Controllers are available for across-the-line starting of the Jockey pump. Manual operation (Hand), by a Hand-Off-Auto selector switch, is independent of the pressure switch system.

In Automatic operation (Auto), the Jockey Pump starts based on pressure. The pressure switch cut-in point is usually set approximately 10psi higher than that of the main controller to cause the Jockey Pump to operate first.

In the event of a fire, the system pressure will drop further to start the main pump.

Our standard Jockey Pump Controller includes: a Motor Starter Protector (MSP) with adjustable overload relays and external reset, a Hand-Off-Auto switch, and a diaphragm type pressure switch.

The standard pressure switch has a range of 30-300psi, a maximum working range of 350psi, a proof pressure of 600psi, and is suitable for fresh water.

This pressure switch is mounted inside the enclosure.

The standard enclosure for our Jockey Pump Controller is a NEMA 3R enclosure painted with a red baked enamel finish.

#### Standard Features:

- Built to NEMA standards
- Protected by Motor Starter Protector with adjustable Overload
- Dual Set Point Pressure Switch – rated 30-300psi
- NEMA 3R Enclosure, complete with safety door interlock
- Hand-Off-Auto Selector Switch
- One N.O. Auxilliary Contact
- Baked Enamel Finish

Patterson Pump Jockey Pump Controllers are assembled, wired and tested at the factory, and ready for immediate installation.

**Instructions**  
**Jockey Pump Controllers**

**WARNING!**

DO NOT ATTEMPT TO INSTALL OR PERFORM MAINTENANCE ON EQUIPMENT WHILE IT IS ENERGIZED! DEATH, PERSONAL INJURY, OR SUBSTANTIAL PROPERTY DAMAGE MAY RESULT FROM CONTACT WITH ENERGIZED EQUIPMENT. ALWAYS VERIFY THAT NO VOLTAGE IS PRESENT BEFORE PROCEEDING, AND ALWAYS FOLLOW GENERALLY ACCEPTED SAFETY PROCEDURES. JOCKEY PUMP CONTROLLER "ON-OFF" HANDLES MUST BE IN THE EXTREME "OFF" POSITION TO OPEN THE ENCLOSURE DOOR. PATTERSON CANNOT BE LIABLE FOR ANY MISAPPLICATION OR INCORRECT INSTALLION OF ITS PRODUCTS.

**MOUNTING CONTROLLER**

**NOTE:** Consult the appropriate job plans to determine the controller mounting location. Tools and materials (wall mounting) required:

1. Assortment of common hand tools of the type used to service electromechanical equipment.
2. Drill for drilling wall anchor holes.
3. Hand level.
4. Tape Measure.
5. Four anchors with bolts and washers, per enclosure.

**MAKING ELECTRICAL CONNECTIONS**

**IMPORTANT PRECAUTIONS:** Prior to mounting the controller and making any field connections:

1. Verify that the following information is compatible with other related equipment on the project:
  - Patterson catalog number
  - Motor horsepower, voltage, phase and frequency
  - System pressure
2. The project electrical contractor must supply all necessary wiring for field connections in accordance with the *National Electrical Code*, the local electrical code and any other authority having jurisdiction.
3. Open the door of the enclosure and inspect the internal components and wiring for any signs of frayed or loose wires or other visible damage.

**PROCEDURE**

All field connections and AC wiring are brought into the enclosure through the bottom or side conduit entrances. Refer to the *National Electrical Code*, the local electrical code or any other authority having jurisdiction for proper conduit entrance location.

1. Use a hole punch, not a torch nor a drill, to punch a hole in the enclosure for the size conduit being used.
2. Install necessary conduit.
3. Pull all wires necessary for field connections, remote alarm functions, AC power and all other optional features. Allow enough excess wire inside the enclosure to make up connections to the appropriate line, load and control terminal block points. Be sure to consult the appropriate field connection diagram included with the manual. For proper wire sizing, refer to the *National Electrical Code*, NFPA 70.
4. Make all field connections to the remote alarm functions and any other optional features. Do not connect AC power.
5. Verify AC line voltage, phase and frequency with the controller data plate on the enclosure door prior to connecting AC power.
6. Connect the AC power.
7. Check to see that all connections are both correctly wired and tight.
8. Close the enclosure door.

**Instructions**  
**Jockey Pump Controllers**

**MAKING SYSTEM PRESSURE CONNECTION**

The controller requires one (1) system pressure connection from the system piping to the enclosure. The connection fitting is provided on the bottom, external side of the enclosure for this purpose. Refer to NFPA 20 (or Publication GF 100-30) for correct field piping procedure of the sensing line between the pumping system and the controller.

**VOLTAGE CHECK**

1. Energize the incoming power feeder.
2. Measure the line voltage at L1, L2 and L3 at the top of the disconnect switch. Confirm that the measured voltage matches the voltage stamped on the data plate.

**SETTING START AND STOP PRESSURES**

The controller is furnished with a pressure switch to control the start and the stop sequence of the jockey pump.

The Start Pressure is set by turning the screw located on top of the pressure switch. The Differential Pressure is set by turning the screw through the hole in the top of the pressure switch. The Stop Pressure is the sum of the start and differential settings (ex. Start @120 psi + differential @ 15 psi = Stop Pressure 135 psi). The upper (STOP) pressure setting must be set at a pressure less than the jockey pump "churn" pressures (including minimum suction pressure) otherwise the pump will run continuously once started.

**CONTROLLER OPERATION**

**FPJPC** – Each controller has a HAND-OFF-AUTO selector switch mounted on the right-hand side for selection of Manual or Automatic operation. When placed in HAND, the motor starter is energized and the motor will run until the switch is placed in OFF. When the switch is placed in AUTO, the motor starter is energized by the pressure switch. Controllers may be furnished with optional Running Period Timers which operate in conjunction with the pressure switch.

**WITHOUT RUNNING PERIOD TIMER** – Controllers without running period timers start and stop automatically as determined directly by the pressure switch settings.

**WITH RUNNING PERIOD TIMER** – Controllers with Running Period Timers start automatically when the system pressure decreased to the pressure switch lower (START) setting and stop only after the timer has completed its timed cycle and the upper (STOP) pressure setting of the pressure switch has been reached.

# STANDARD JOCKEY PUMP CONTROLLER NEMA TYPE 3R ENCLOSURE

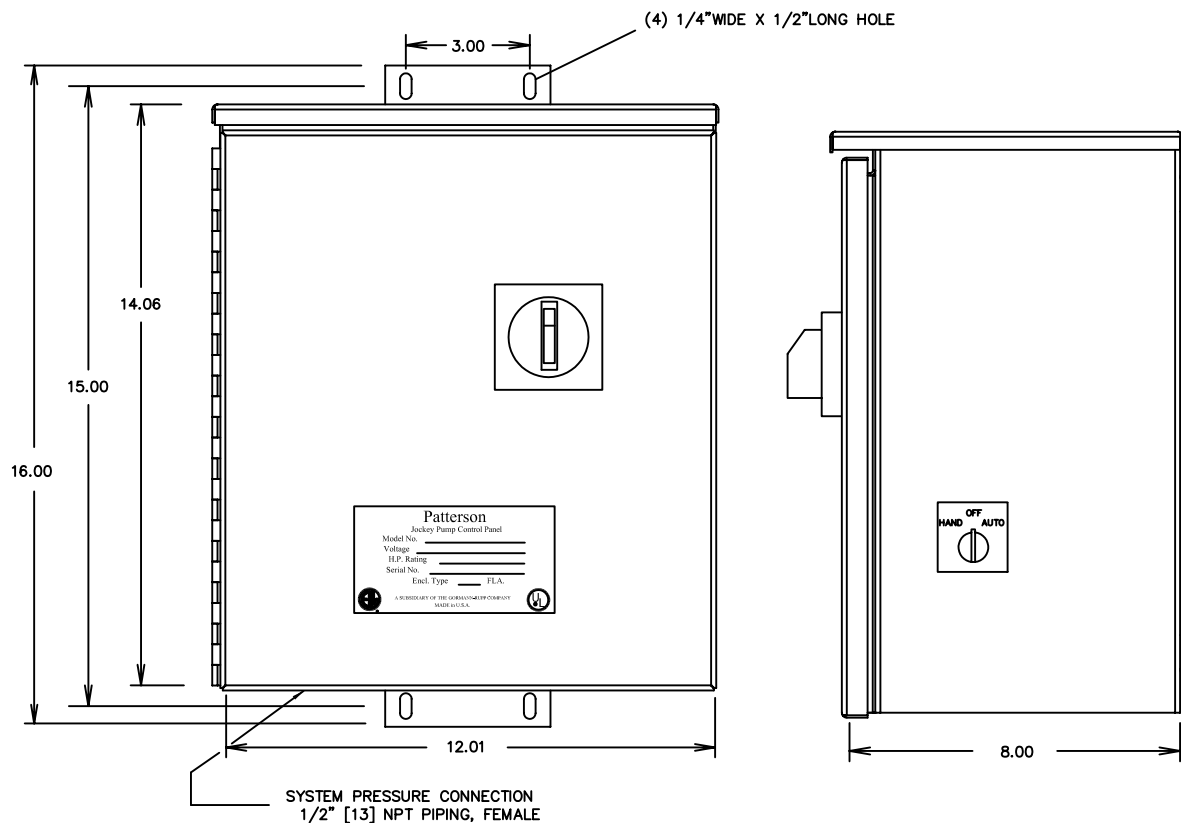

## STANDARD JOCKEY PUMP CONTROLLER ELECTRICAL SCHEMATIC

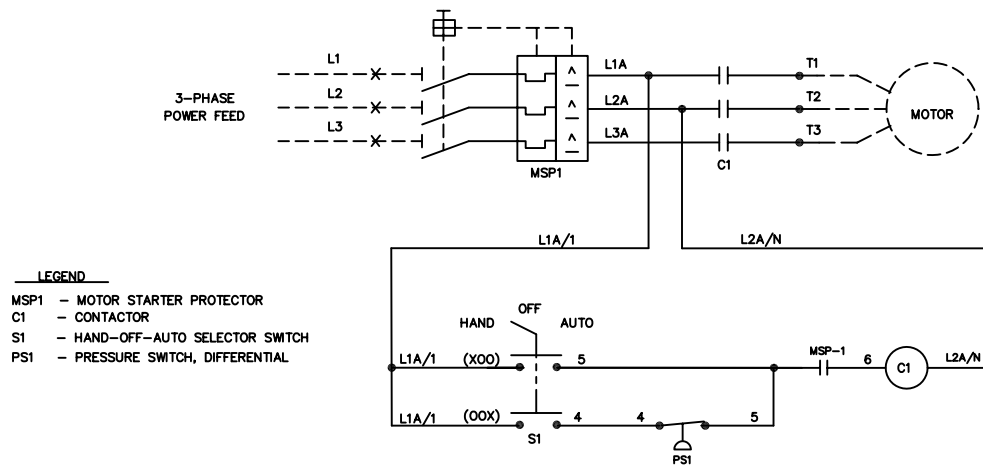

### STANDARD RATINGS

HORSEPOWER	VOLTAGE	WIRE SIZE (CU) PER PHASE
0.5 - 10	575/3/60	(1) #14 AWG (1) [2.0 MM SQ.]
0.5 - 10	480/3/60	(1) #14 AWG (1) [2.0 MM SQ.]
0.5 - 10	380/3/50	(1) #14 - #8 AWG. (1) [2 - 8 MM SQ.]
0.5 - 10	240/3/60	(1) #8 AWG. (1) [8 MM SQ.]
0.5 - 10	208/3/60	(1) #8 AWG. (1) [8 MM SQ.]
0.33 - 2	120/1/60	(1) #10 AWG (1) [5 MM SQ.]
0.33 - 2	240/1/60	(1) #14 AWG (1) [2 MM SQ.]

### NOTES:

- ENCLOSURE MADE FROM 16 GA. STEEL.
- ENTER EITHER TOP OR BOTTOM.
- WALL MOUNTING.
- STANDARD PADLOCKABLE DRAW LATCH NOT SHOWN.
- MERCOID PRESSURE SWITCH CAN BE SUPPLIED AS AN OPTION. (REQUIRES A 16X12X8 ENCLOSURE)
- STANDARD ENCLOSURE NEMA TYPE 3R.
- FINISH: RED PAINTED BAKED ENAMEL FINISH.
- INTERRUPTING CAPACITY 65kA UP TO 480VAC.
- CONNECT TRANSFORMER PER PRIMARY VOLTAGE REQUIREMENTS.

# JOCKEY PUMP CONTROLLER OPTIONS AND MODIFICATIONS

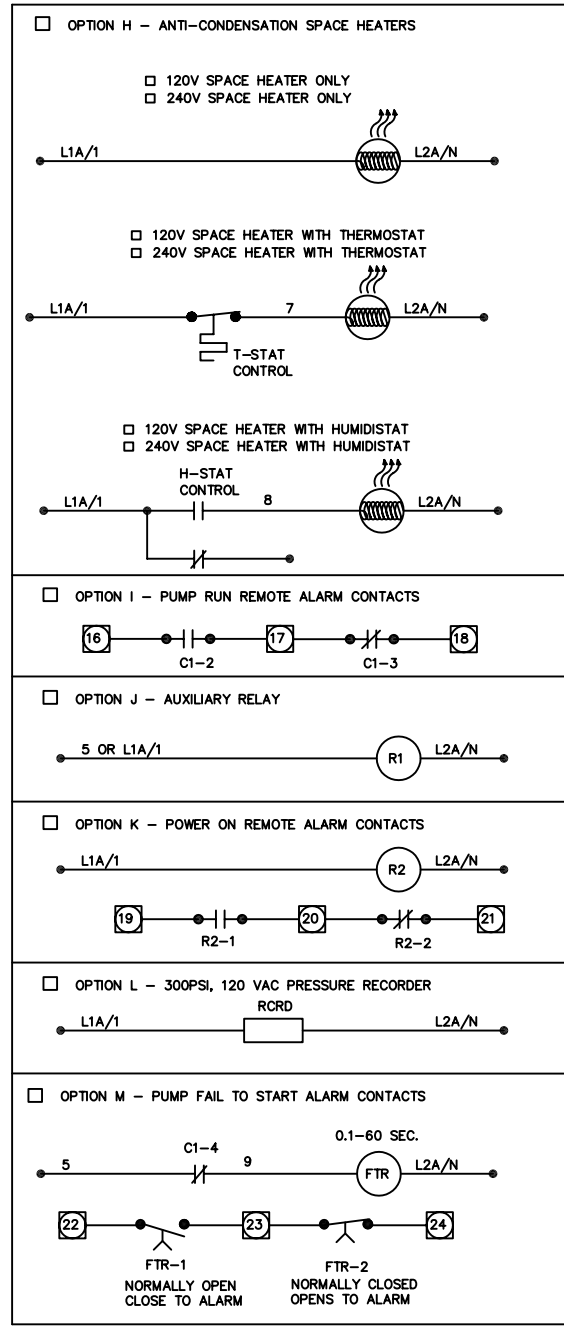
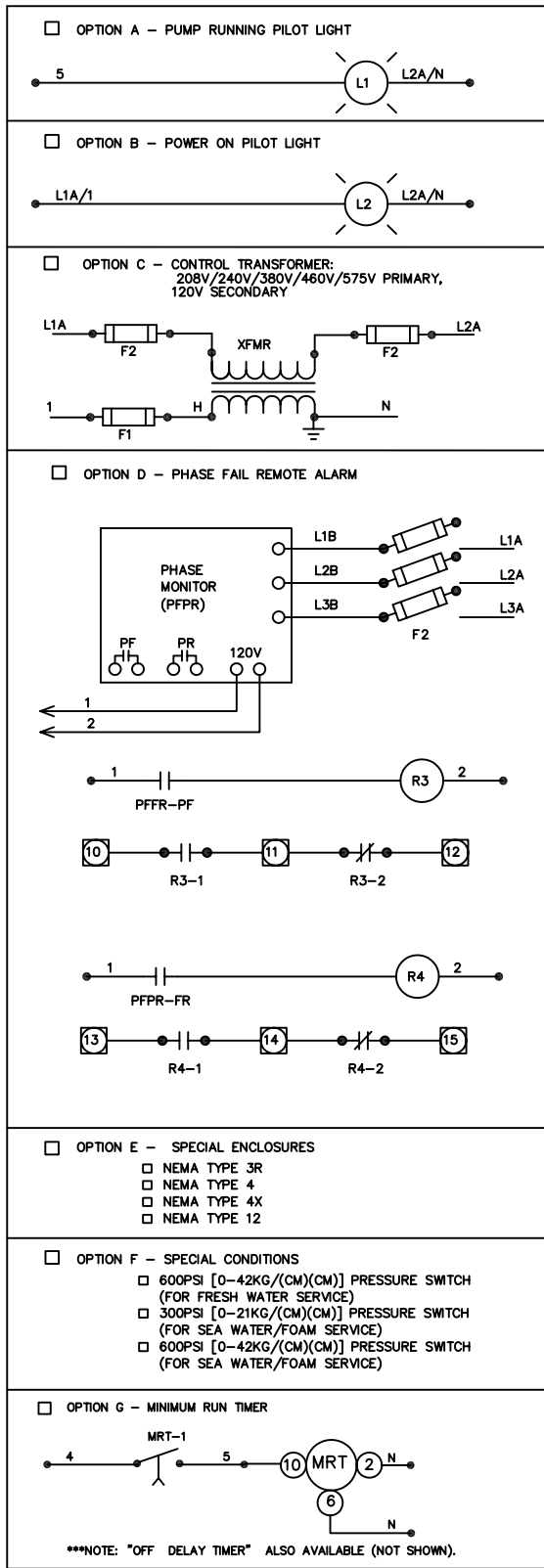

HORSEPOWER, HP	
.33	<input type="checkbox"/>
0.5	<input type="checkbox"/>
0.75	<input type="checkbox"/>
1.0	<input type="checkbox"/>
1.5	<input type="checkbox"/>
2.0	<input type="checkbox"/>
3.0	<input type="checkbox"/>
5.0	<input type="checkbox"/>
7.5	<input type="checkbox"/>
10	<input type="checkbox"/>
15	<input type="checkbox"/>
20	<input type="checkbox"/>
25	<input type="checkbox"/>
30	<input type="checkbox"/>
40	<input type="checkbox"/>
50	<input type="checkbox"/>

VOLTAGE, VAC	
120V	<input type="checkbox"/>
208V	<input type="checkbox"/>
240V	<input type="checkbox"/>
380V	<input type="checkbox"/>
460V	<input type="checkbox"/>
575V	<input type="checkbox"/>

FREQUENCY, HZ	
50HZ	<input type="checkbox"/>
60HZ	<input type="checkbox"/>

PHASE	
1	<input type="checkbox"/>
3	<input type="checkbox"/>

SHIPPING WEIGHT  
(APPROXIMATE)  
25 LBS. (9KG)



**FLO-PAK IS LISTED BY ETL UNDER ELECTRIC INDUSTRIAL CONTROL EQUIPMENT FILE# 79045. ALL ASSEMBLY AND WIRING OF FLO-PAK CONTROL PANELS IS IN ACCORDANCE WITH UL 508 AND NATIONAL ELECTRIC CODE NFPA 70 STANDARDS. FLO-PAK CANNOT BE RESPONSIBLE FOR MORE RESTRICTIVE LOCAL OR REGIONAL CODES UNLESS SUCH CODES HAVE BEEN IDENTIFIED PRIOR TO FABRICATION.**

# SELECTION DATA SHEET for JOCKEY PUMP CONTROLLERS

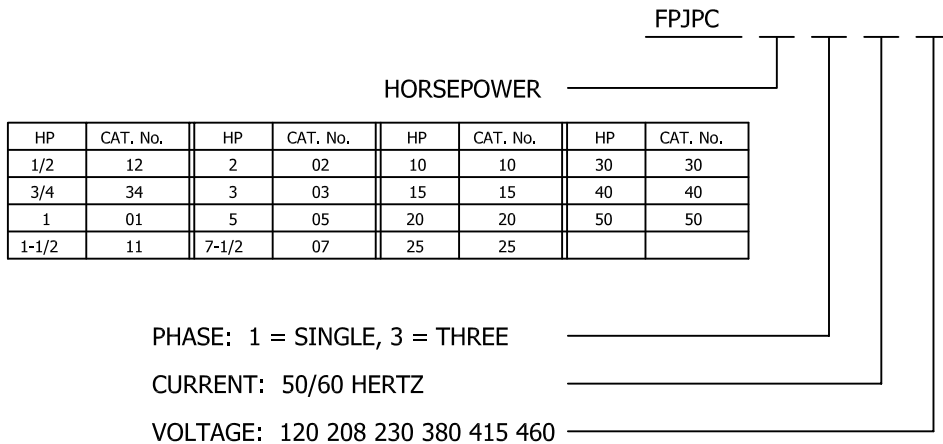

PHASE: 1 = SINGLE, 3 = THREE

CURRENT: 50/60 HERTZ

VOLTAGE: 120 208 230 380 415 460

### OPTIONAL FEATURES:

- 1  PUMP RUNNING PILOT LIGHT
- 2  POWER ON PILOT LIGHT
- 3  CONTROL CIRCUIT TRANSFORMER
- 4  PHASE FAIL/PHASE REVERSAL REMOTE ALARM
- 5  PUMP RUN REMOTE ALARM CONTACTS
- 6  AUXILIARY RELAY
- 7  POWER ON REMOTE ALARM CONTACTS
- 8  300PSI, 120VAC PRESSURE RECORDER
- 9  FAIL TO START ALARM CONTACTS
- 10  RUNNING PERIOD TIMER

### MODIFICATIONS:

#### SPECIAL ENCLOSURES:

- N2  NEMA TYPE 4
- N3  NEMA TYPE 4X
- N4  NEMA TYPE 12

#### ANTI-CONDENSATION SPACE HEATERS:

- H1  120 VOLT SPACE HEATER
- H2  240 VOLT SPACE HEATER
- H3  120 VOLT SPACE HEATER WITH THERMOSTAT
- H4  240 VOLT SPACE HEATER WITH THERMOSTAT
- H5  120 VOLT SPACE HEATER WITH HUMIDISTAT
- H6  240 VOLT SPACE HEATER WITH HUMIDISTAT

#### SPECIAL CONDITIONS:

- P1  0-600 PSI (0-42 kg/cm<sup>2</sup>) PRESSURE SWITCH FOR FRESH WATER SERVICE
- P2  0-300 PSI (0-21 kg/cm<sup>2</sup>) PRESSURE SWITCH FOR SEAWATER/FOAM SERVICE
- P3  0-600 PSI (0-42 kg/cm<sup>2</sup>) PRESSURE SWITCH FOR SEAWATER/FOAM SERVICE

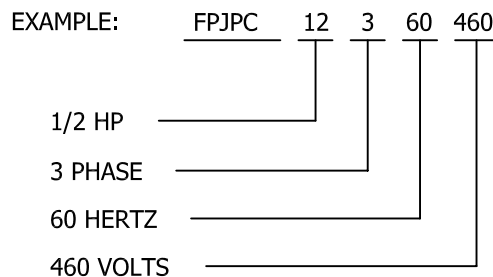

### STANDARD FEATURES:

- BUILT TO NEMA STANDARDS
- MAGNETIC MOTOR STARTER AND MSP WITH ADJUSTABLE OVERLOAD
- THROUGH-THE-DOOR DISCONNECT SWITCH CONNECTED TO MOTOR STARTER PROTECTOR (MSP)
- PRESSURE SWITCH WITH EXTERNAL SETPOINT ADJUSTMENT AND DEADBAND ADJUSTMENT
- NEMA 3R ENCLOSURE COMPLETE WITH SAFETY DOOR INTERLOCK
- HAND-OFF-AUTO SELECTOR SWITCH
- BAKED ENAMEL FINISH

*Patterson - Flo-Pak Jockey Pump Controllers are built to NEMA industrial standards and are UL 508 listed and ETL Certified. These controllers are intended for use with fire pump systems.*

*The standard Jockey Pump Controller includes a diaphragm type pressure switch, and a magnetic motor starter and MSP with thermal overload and external reset switch button.*

*The standard pressure switch has a range of 30-300 psi (2.1 to 20.7 BAR) and is suitable for fresh water. This pressure switch is mounted inside the enclosure.*

*The standard enclosure is a NEMA 3R enclosure painted with a red baked enamel finish.*

**General Information**  
**Typical Pressure Sensing Line Connection**  
**Fire Pump Controllers & Jockey Pump Controllers**

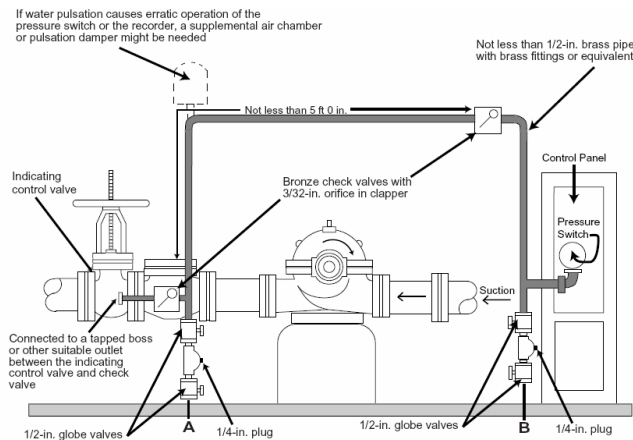

**Figure A-7-5.2.1(a) Piping connection for each automatic pressure switch (for fire pump and jockey pumps).**

If water is clean, ground-face unions with noncorrosive diaphragms drilled for 3/32-in. orifices can be used in place of the check valves.

For SI units, 1 in. = 25.4mm; 1 ft. = 0.3048m.

Note: Solenoid drain valve used for engine-driven fire pumps can be at A, B, or inside of controller enclosure.

Test connection at A or B

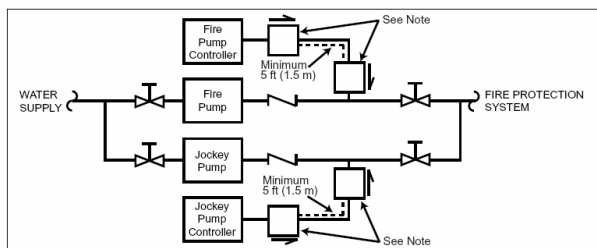

**Figure A-7-5.2.1(b) Piping connection for pressure-sensing line.**

Note: Check valves or ground-face unions complying with 7-5.2.1.

**NFPA 20**

**7-5.2.1 Water Pressure Control** – There shall be provided a pressure – actuated switch having independent high and low calibrated adjustments in the controller circuit. There shall be no pressure snubber or restrictive orifice employed within the pressure switch. This switch shall be responsive to water pressure in the fire protection system. The pressure sensing element of the switch shall be capable of withstanding a momentary surge pressure of 400 psi (27.6 bar) without losing its accuracy. Suitable provision shall be made for relieving pressure to the pressure-actuated switch to allow testing of the operation of the controller and the pumping unit. [See Figures A-7-5.2.1 (a) and (b).]

- (a) For all pump installations, including jockey pumps, each controller shall have its own individual pressure sensing line.
- (b) The pressure sensing line connection for each pump, including jockey pumps, shall be made between that pump's discharge check valve and discharge control valve. This line shall be brass, copper, or series 200 stainless steel pipe or tube, and the fitting shall be of ½ inch (12.7 mm) nominal size. There shall be two check valves installed in the pressure sensing line at least 5 ft. (1.5 m) apart with a 3/32 inch (2.4 mm) hole drilled in the clapper to serve as dampening. [See Figures A-7-5.2.1 (a) and (b).]

**Exception No. 1:** If water is clean, ground-face unions with noncorrosive diaphragms drilled with 3/32-in. (2.4 mm) orifices shall be permitted in place of the check valves.

**Exception No. 2:** In a nonpressure-actuated controller, the pressure-actuated switch shall not be required.

- (c) There shall be no shutoff valve in the pressure-sensing line.
- (d) Pressure switch actuation at the low adjustment setting shall initiate pump starting sequence (if pump is not already in operation).
- (e) A listed pressure recording device shall be installed to sense and record the pressure in each fire pump controller pressure-sensing line at the input to the controller. The pressure recorder shall be capable of operating for at least seven days without being reset or rewind.

The pressure sensing element of the recorder shall be capable of withstanding a momentary surge pressure of at least 400 psi (27.6 bar) without losing its accuracy.

**A-7-5.2.1** Installation of the pressure-sensing line in between the discharge check valve and the control valve is necessary to facilitate isolation of the jockey pump controller (and sensing line) for maintenance without having to drain the entire system. [See Figures A-7-5.2.1 (a) and (b).]

**A-7.5.2.1(e)** The pressure recorder should be able to record a pressure at least 150 percent of the pump discharge pressure under no-flow conditions. In a high-rise building this requirement can exceed 400 psi (27.6 bar). This pressure recorder should be readable without opening the fire pump controller enclosure. This requirement does not mandate a separate recording device for each controller. A single multichannel recording device can serve multiple sensors.